

IMPROVE YOUR MACHINE BE BETTER

QUICK COUPLER SYSTEMS
FOR EXCAVATORS





QUICK COUPLER SYSTEMS
FOR MAXIMUM PERFORMANCE

1 WHO WE ARE pp. 4-5

2 OPERATING PRINCIPLE pp. 6-7

3 CERTIFIED SAFETY pp. 10-13

4 OQ PRODUCT RANGE pp. 14-29

5 SPECIAL SOLUTIONS pp. 30-33

6 OPTIONAL EQUIPMENT p. 36

7 OQ TOOL CONTROL p. 37

8 PARTNER PROGRAMME p. 38

9 WHAT OUR CUSTOMERS SAY p. 39

10 OILQUICK ACADEMY pp. 40-41

11 UPGRADE p. 42

12 CONTACT p. 43

THE ORIGINAL PIONEER SINCE 1993

Almost 30 years ago, OilQuick launched the first fully hydraulic quick coupler, revolutionising the construction industry. We are still visionaries and our quick couplers continue to define the state of the art. Every day, our engineers work

on groundbreaking innovations that allow attachments to be changed even more quickly.

Our aim: We develop products that improve your work. Making your day-to-day construction site operation more efficient, convenient and safe.



EFFICIENCY

With OilQuick quick couplers your excavator turns into a multifunctional tool holder, giving you the right tool for any situation on the construction site. Coupling and uncoupling works directly from the cab, without the use of tools or handling oil-contaminated couplings.



SAFETY

Visual display, drop guard, acoustic and optical warning signal, redundant hose break valves and hydraulic retightening of the locking bolts: We redefine safety and significantly lower the risk of accidents at construction sites.

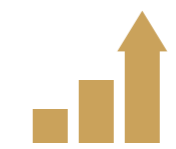

OPERATING EFFICIENCY

An investment in OilQuick quick couplers not only increases your productivity, but also pays off economically: At just a few tool changes a day, the investment pays for itself from short changeover times and more intelligent work processes!



SERVICE

For us, performance and sustainability not only have to do with product quality, but also with service. That's why we also develop individual special solutions, retrofit innovations to existing equipment and offer a worldwide network of dealers and service centres.

FOR EVERYONE WITH BIG PLANS WE MAKE YOU MORE EFFICIENT!

Mini excavator or heavy equipment? Mechanical or hydraulic tool? Every fleet is different, but the OilQuick operating principle always fits. And the result too: you'll work more comfortably, faster and safer. No matter what equipment, in the OilQuick range of products you will find the right quick coupler and adapter for all attachments. Our promise to you: We'll match our quick coupler with your excavator.



HYDRAULIC FRAMES



SCREW ADAPTERS FOR MANY POPULAR ATTACHMENTS



MECHANICAL FRAMES



HYDRAULIC PENDULUM ADAPTERS

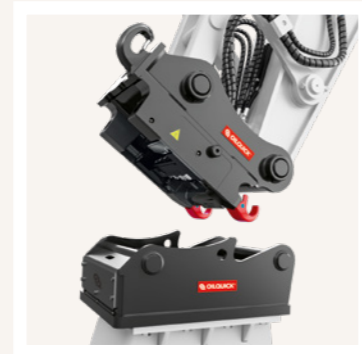

TOOL CHANGE FROM THE CAB

ONE...



TWO...



GO!

FUNCTIONALITY AND SAFETY WELL THOUGHT-OUT DOWN TO THE LAST DETAIL

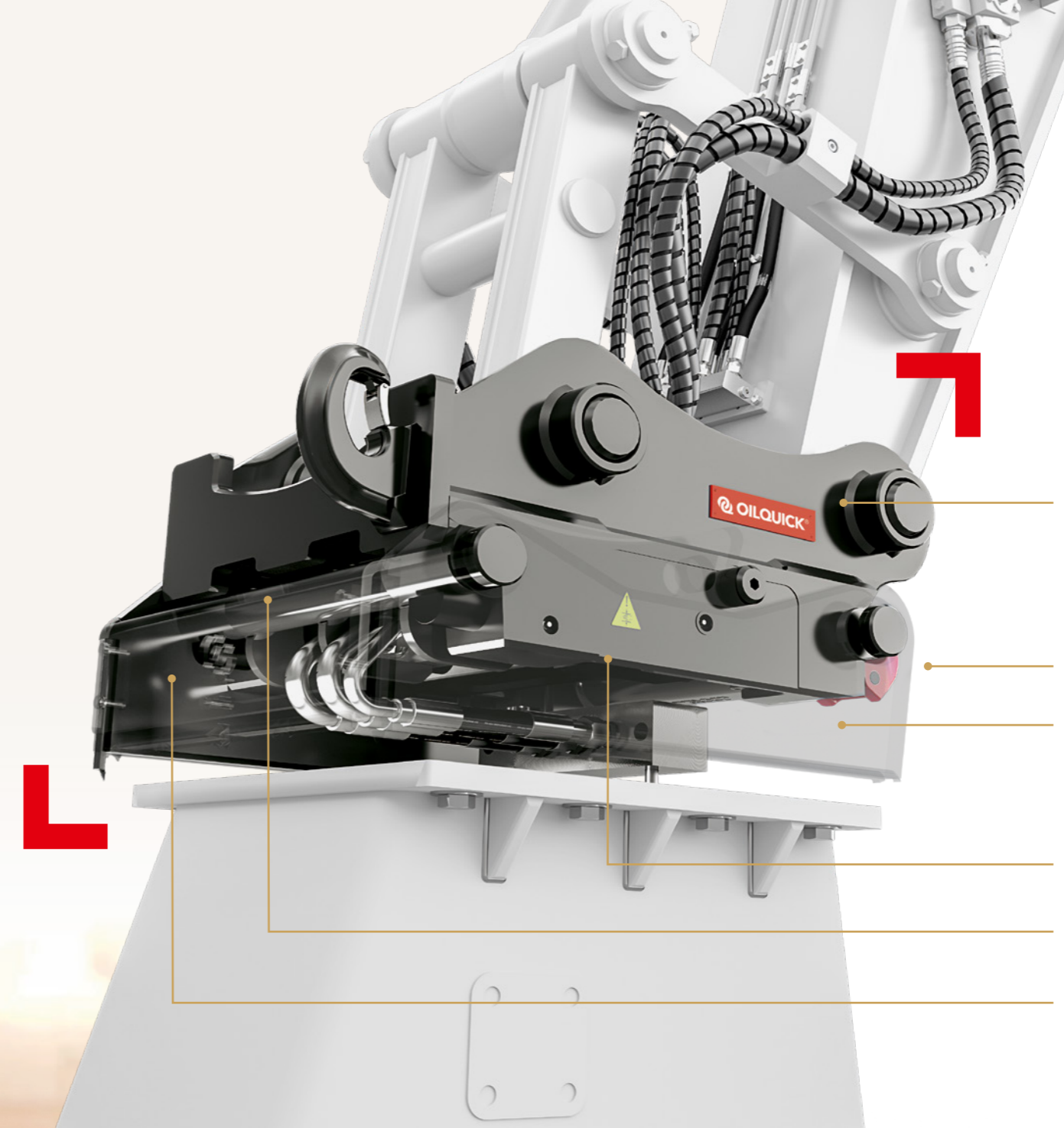

Robust quick coupler – precise, made of high quality steel

Drop guard to protect against falling attachments

wear-free OilQuick adapter frames with loading aid

H-cylinder with quick couplings: connect hydraulic circuits and lock quick couplers with a single cylinder movement

Tag reader for automatic tool identification (optional)

Redundant pressure retention valves – for a secure connection even if a hose breaks

»There is nothing better for a business that has to change tools several times a day!«



UNDENIABLY EFFICIENT

A fully hydraulic OilQuick quick coupler not only reduces change-over times, but also increases your excavator's range of applications. According to the figures: Our customers can increase their machine utilisation by up to 90 percent and improve their fleet productivity by an average of 30 percent.



CLEAN SYSTEM: THE PARTNER PROGRAMME FOR CERTIFIED SAFETY

When we guarantee your safety, for us this also means the smooth operation and long service life of our quick couplers. Which is why we introduced the Clean System Seal in 2019: Dealers and rental fleets can voluntarily undertake to not combine OilQuick quick couplers with products from other manufacturers and to only use genuine spare parts.

The background: Experience has shown that combining different quick coupler systems leads to incalculable risks, for example increased wear and tear, electronic malfunctions or a contaminated oil circuit may occur during mixed operation. This is why we use homogeneous systems, together with our dealers.

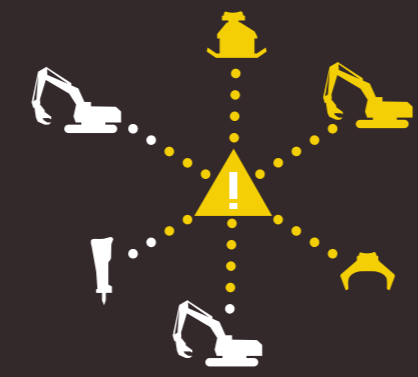

Danger of contamination during mixed operation



A clean, homogeneous system

AWARD-WINNING OCCUPATIONAL SAFETY INNOVATIONS AT THE CUTTING EDGE OF THE SECTOR

Our engineers are continuously developing the OilQuick quick coupler. We have your back – with well thought-out user functions, advanced occupational safety ideas and digital features. This also impress experts in the field: Berufsgenossenschaft der Bauwirtschaft (BG Bau, statutory accident insurance for construction and construction-related services in Germany) awarded OilQuick the EuroTest Prize 2019 for its "outstanding technical occupational safety and product safety" achievements.



**SMARTER:
VISUAL DISPLAY**



**SAFER:
DROP GUARD**



**MORE EFFICIENT:
OILQUICK APP**



**YOUR SAFETY
REDEFINED**

- VISUAL DISPLAY
- DROP GUARD
- CLEAN SYSTEM

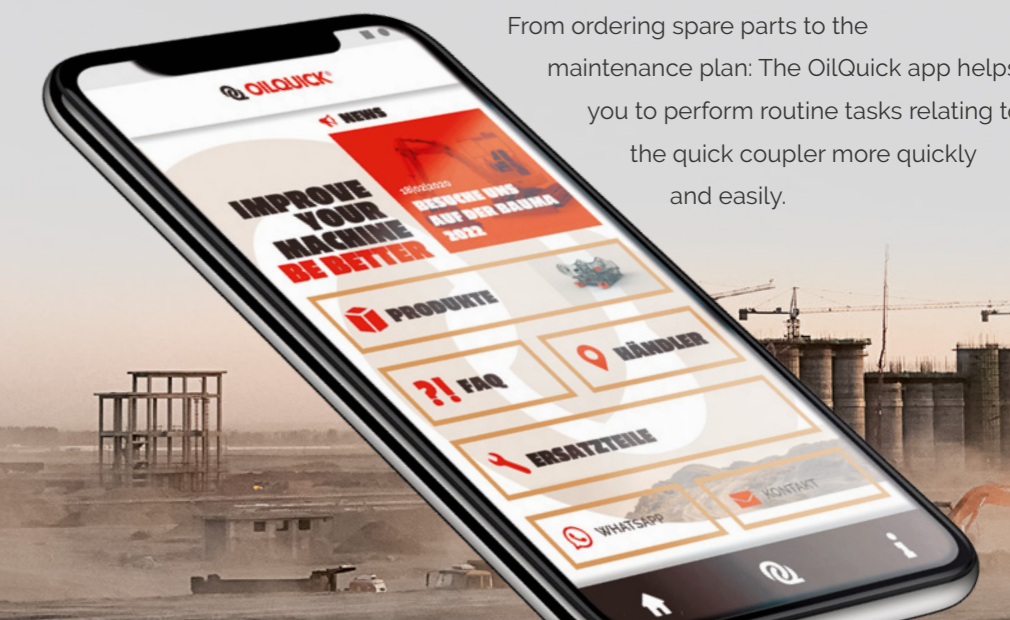

From ordering spare parts to the maintenance plan: The OilQuick app helps you to perform routine tasks relating to the quick coupler more quickly and easily.



DROP GUARD: THE EXTRA BENEFIT FOR YOUR SAFETY

Even if the quick coupler lock has not been closed properly, despite the visual display, warning signal and cross check: The safety catch will prevent attachments from falling and injuring you or your colleagues. The movable and replaceable drop guard extends the quick coupler claw, which closes around the shaft at the attachment adaptor – a reliable mechanical measure for accident prevention.



VISUAL MRL DISPLAY: CORRECT LOCKING GUARANTEED

"Simple and robust, please!" That was the locking control requirement of the machine operators we surveyed. Implementation was a bit tricky. In order to rule out misinterpretations, the usual combinations of different coloured pins for different locking situations in use till now were out of the question. Our new visual MRL display allows you to quickly and clearly see whether the quick coupler is locked correctly: If it is green, then it is OK! Without the use of sensors and electronics. Another advantage: From the machine operator's point of view, the large pin moves horizontally and is thus 650 percent more easily perceived.

Visual MRL display

Visual display green:
correctly locked

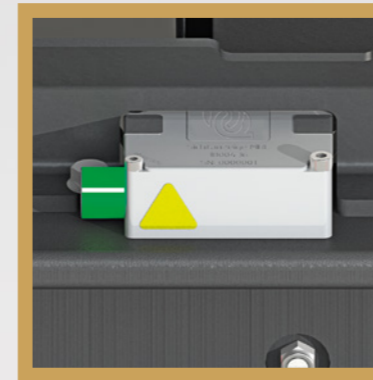

Drop guard



DID YOU KNOW THIS?



You can have older quick coupler models upgraded at any time – and this is subsidised by BG Bau!

OQ

THE BEST FOR YOUR EXCAVATOR

Swivel buckets, clamshell buckets, concrete crushers, compactors, forestry tongs or hydraulic hammer: We supply the right quick couplers for any application. For mini excavators and large construction machinery of up to 120 tonnes. From landscaping to civil

engineering, from demolition to railway construction: Tuning tip: Do you have mechanical or hydraulic OilQuick quick couplers in stock and want to get even more out of your fleet? We would be happy to advise you on an upgrade and upgrade your used ones!

IMPRESSIVELY VERSATILE

Excavating or milling, modelling embankments or tree maintenance work, often in rapid succession and in a very confined space: For landscaping projects, you need versatile universal talents that enable flexible machine deployment.

»The OilQuick quick coupler makes our mini and compact excavators powerful all-rounders.«



OQ 40

FULLY AUTOMATIC QUICK COUPLER SYSTEM FOR MINI EXCAVATORS FROM 1 TO 5 TONNES

The quick coupler for all applications where manoeuvrability is particularly important or where working space is limited – from landscaping and small renovation projects to forestry.



FRAMES FOR MECHANICAL EQUIPMENT

Inner width (mm) 240 mm
Centre distance (mm) 300 mm
Axle diameter (mm) 40 mm
Weight (kg) approx. 15 kg



FRAMES FOR HYDRAULIC EQUIPMENT

240 mm
300 mm
40 mm
approx. 26 kg



SCREW ADAPTERS FOR MANY POPULAR ATTACHMENTS

240 mm
300 mm
40 mm
approx. 50 kg



HYDRAULIC PENDULUM ADAPTERS

240 mm
300 mm
40 mm
approx. 40 kg



COUPLER WITH TWO PARALLEL HYDRAULIC CYLINDERS

Max. working pressure 35 MPa
Pressure retention/hose break valves yes

NON-DRIP QUICK COUPLERS MADE OF STEEL, OILQUICK TYPE

Coupling size 1/4" 1/2"
Number of couplings 2 2

LOAD HOOKS

individually configurable

OQ 40-5

FULLY AUTOMATIC QUICK COUPLER SYSTEM FOR MINI EXCAVATORS FROM 1 TO 6 TONNES

The quick coupler for mini excavators – concentrated power with high mobility, for all applications on small construction sites.



FRAMES FOR MECHANICAL EQUIPMENT

Inner width (mm) 270 mm
Centre distance (mm) 300 mm
Axle diameter (mm) 40 mm
Weight (kg) approx. 15 kg



FRAMES FOR HYDRAULIC EQUIPMENT

270 mm
300 mm
40 mm
approx. 26 kg



SCREW ADAPTERS FOR MANY POPULAR ATTACHMENTS

270 mm
300 mm
40 mm
approx. 50 kg



HYDRAULIC PENDULUM ADAPTERS

270 mm
300 mm
40 mm
approx. 40 kg



COUPLER WITH TWO PARALLEL HYDRAULIC CYLINDERS

Max. working pressure 35 MPa
Pressure retention/hose break valves yes

NON-DRIP QUICK COUPLERS MADE OF STEEL, OILQUICK TYPE

Coupling size 1/4" 1/2"
Number of couplings 3 2

LOAD HOOKS

individually configurable

FRAMES FOR MECHANICAL EQUIPMENT

Inner width (mm) 290 mm
 Centre distance (mm) 430 mm
 Axle diameter (mm) 45 mm
 Weight (kg) approx. 29 kg



FRAMES FOR HYDRAULIC EQUIPMENT

290 mm
 430 mm
 45 mm
 approx. 40 kg



SCREW ADAPTERS FOR MANY POPULAR ATTACHMENTS

290 mm
 430 mm
 45 mm
 approx. 85 kg



HYDRAULIC PENDULUM ADAPTERS

290 mm
 430 mm
 45 mm
 approx. 65 kg



COUPLER WITH TWO PARALLEL HYDRAULIC CYLINDERS

Max. working pressure 35 MPa
 Pressure retention/hose break valves yes

NON-DRIP QUICK COUPLERS MADE OF STEEL, OILQUICK TYPE

Coupling size 1/4" 1/2"
 Number of couplings 3 2

ELECTRIC COUPLERS (OPTIONAL)

2 x V90

See page 36 for additional information.

LOAD HOOKS

individually configurable



OQ 45-5

FULLY AUTOMATIC QUICK COUPLER SYSTEM FOR EXCAVATORS FROM 5 TO 12 TONNES

The quick coupler for compact excavators – ideal for light earthworks and landscaping.

FRAMES FOR MECHANICAL EQUIPMENT

Inner width (mm) 340 mm
 Centre distance (mm) 480 mm
 Axle diameter (mm) 60 mm
 Weight (kg) approx. 49 kg



FRAMES FOR HYDRAULIC EQUIPMENT

340 mm
 480 mm
 60 mm
 approx. 67 kg



SCREW ADAPTERS FOR MANY POPULAR ATTACHMENTS

340 mm
 480 mm
 60 mm
 approx. 155 kg



HYDRAULIC PENDULUM ADAPTERS

340 mm
 480 mm
 60 mm
 approx. 115 kg



COUPLER WITH TWO PARALLEL HYDRAULIC CYLINDERS

Max. working pressure 35 MPa
 Pressure retention/hose break valves yes

NON-DRIP QUICK COUPLERS MADE OF STEEL, OILQUICK TYPE

Coupling size 1/4" 1/2" 3/4"
 Number of couplings 2 1 2

ELECTRIC COUPLERS (OPTIONAL)

2 x V90

See page 36 for additional information.

LOAD HOOKS

individually configurable

OQ 60-5

FULLY AUTOMATIC QUICK COUPLER SYSTEM FOR EXCAVATORS FROM 8 TO 15 TONNES

The quick coupler for light mid-range excavators – the all-rounder on construction sites and for simpler earthmoving works.







UNCOMPROMISINGLY RATIONAL

Canal construction, earth movement or roadworks: Due to its mostly time-critical contracts, civil engineering requires efficient building site organisation, as well as powerful equipment. Fully automated device exchanges are therefore a major prerequisite for financial calculations and will improve your competitiveness when tendering.



»On civil engineering sites, we have up to 100 tool changes per day. Without OilQuick, we would be unable to complete these 'in time'.«

	<p>FRAMES FOR MECHANICAL EQUIPMENT</p> <p>Inner width (mm) 440 mm Centre distance (mm) 530 mm Axle diameter (mm) 65 mm Weight (kg) approx. 70 kg</p> 	<p>FRAMES FOR HYDRAULIC EQUIPMENT</p> <p>440 mm 530 mm 65 mm approx. 90 kg</p> 	<p>SCREW ADAPTERS FOR MANY POPULAR ATTACHMENTS</p> <p>440 mm 530 mm 65 mm approx. 210 kg</p> 	<p>HYDRAULIC PENDULUM ADAPTERS</p> <p>440 mm 530 mm 65 mm approx. 155 kg</p> 
	<p>COUPLER WITH TWO PARALLEL HYDRAULIC CYLINDERS</p> <p>Max. working pressure 35 MPa Pressure retention/hose break valves yes</p>	<p>NON-DRIP QUICK COUPLERS MADE OF STEEL, OILQUICK TYPE</p> <p>Coupling size 1/2" 3/4" Number of couplings 2 3</p>	<p>ELECTRIC COUPLERS (OPTIONAL) 2 x U90</p> <p>See page 36 for additional information.</p>	<p>LOAD HOOKS</p> <p>individually configurable</p>

OQ 65

FULLY AUTOMATIC QUICK COUPLER SYSTEM FOR EXCAVATORS FROM 14 TO 22 TONNES

The quick coupler for mid-range excavators – with a wide range of applications including building construction and infrastructure works.



FRAMES FOR MECHANICAL EQUIPMENT

Inner width (mm) 440 mm
 Centre distance (mm) 530 mm
 Axle diameter (mm) 65 mm
 Weight (kg) approx. 70 kg



FRAMES FOR HYDRAULIC EQUIPMENT

440 mm
 530 mm
 65 mm
 approx. 90 kg



SCREW ADAPTERS FOR MANY POPULAR ATTACHMENTS

440 mm
 530 mm
 65 mm
 approx. 210 kg



HYDRAULIC PENDULUM ADAPTERS

440 mm
 530 mm
 65 mm
 approx. 155 kg



COUPLER WITH TWO PARALLEL HYDRAULIC CYLINDERS

Max. working pressure 35 MPa
 Pressure retention/hose break valves yes

NON-DRIP QUICK COUPLERS MADE OF STEEL, OILQUICK TYPE

Coupling size 1/2" 3/4"
 Number of couplings 5 3

ELECTRIC COUPLERS (OPTIONAL) 2 x V90

See page 36 for additional information.

LOAD HOOKS

individually configurable

OQ RAIL

FULLY AUTOMATIC QUICK COUPLER SYSTEM FOR RAIL

The quick coupler for road-rail excavators and work typical in railway construction.



DID YOU KNOW THIS?

A market innovation! The first rail quick coupler with up to 10 couplings – so you can change any attachment without leaving the cab!

»Due to the heavy time pressure, with trains sometimes in continuous operation on railway construction sites, attachments on our rail-road excavators must be able to be changed very quickly and easily.«

EXCEPTIONALLY RELIABLE

Laying sleepers or positioning rails, gravelling and mulching, in the area or on rails: Our new rail quick coupler is designed to improve efficiency in railway construction through the intelligent use of tools. For short blocking times, high fleet productivity and greater safety at work.







OQ 70

FULLY AUTOMATIC QUICK COUPLER SYSTEM FOR MID-RANGE EXCAVATORS FROM 15 TO 28 TONNES

The quick coupler for heavy-duty mid-range excavators – popular for demolition, earthmoving and more.







<p>FRAMES FOR MECHANICAL EQUIPMENT</p> <p>Inner width (mm) 450 mm Centre distance (mm) 600 mm Axle diameter (mm) 70 mm Weight (kg) approx. 85 kg</p> 	<p>FRAMES FOR HYDRAULIC EQUIPMENT</p> <p>450 mm 600 mm 70 mm approx. 117 kg</p> 	<p>SCREW ADAPTERS FOR MANY POPULAR ATTACHMENTS</p> <p>450 mm 600 mm 70 mm approx. 270 kg</p> 	<p>HYDRAULIC PENDULUM ADAPTERS</p> <p>450 mm 600 mm 70 mm approx. 175 kg</p> 								
<p>COUPLER WITH TWO PARALLEL HYDRAULIC CYLINDERS</p> <p>Max. working pressure 35 MPa Pressure retention/hose break valves yes</p>	<p>NON-DRIP QUICK COUPLERS MADE OF STEEL, OILQUICK TYPE</p> <table border="0"> <tr> <td>Coupling size</td> <td>1/2"</td> <td>3/4"</td> <td>1"</td> </tr> <tr> <td>Number of couplings</td> <td>2</td> <td>1</td> <td>2</td> </tr> </table>	Coupling size	1/2"	3/4"	1"	Number of couplings	2	1	2	<p>ELECTRIC COUPLERS (OPTIONAL) 2 x V90</p> <p>See page 36 for additional information.</p>	<p>LOAD HOOKS</p> <p>individually configurable</p>
Coupling size	1/2"	3/4"	1"								
Number of couplings	2	1	2								

OQ 70/55

FULLY AUTOMATIC QUICK COUPLER SYSTEM FOR MID-RANGE EXCAVATORS FROM 18 TO 32 TONNES

The classic amongst quick couplers – present at most construction sites and rental fleets.







<p>FRAMES FOR MECHANICAL EQUIPMENT</p> <p>Inner width (mm) 550 mm Centre distance (mm) 600 mm Axle diameter (mm) 70 mm Weight (kg) approx. 90 kg</p> 	<p>FRAMES FOR HYDRAULIC EQUIPMENT</p> <p>550 mm 600 mm 70 mm approx. 128 kg</p> 	<p>SCREW ADAPTERS FOR MANY POPULAR ATTACHMENTS</p> <p>550 mm 600 mm 70 mm approx. 295 kg</p> 	<p>HYDRAULIC PENDULUM ADAPTERS</p> <p>550 mm 600 mm 70 mm approx. 195 kg</p> 								
<p>COUPLER WITH TWO PARALLEL HYDRAULIC CYLINDERS</p> <p>Max. working pressure 35 MPa Pressure retention/hose break valves yes</p>	<p>NON-DRIP QUICK COUPLERS MADE OF STEEL, OILQUICK TYPE</p> <table border="0"> <tr> <td>Coupling size</td> <td>1/2"</td> <td>3/4"</td> <td>1"</td> </tr> <tr> <td>Number of couplings</td> <td>2</td> <td>2</td> <td>2</td> </tr> </table>	Coupling size	1/2"	3/4"	1"	Number of couplings	2	2	2	<p>ELECTRIC COUPLERS (OPTIONAL) 3/4 2 x V90</p> <p>See page 36 for additional information.</p>	<p>LOAD HOOKS</p> <p>individually configurable</p>
Coupling size	1/2"	3/4"	1"								
Number of couplings	2	2	2								

»During demolition, we must be able to rely 100% on our machines. The robust OilQuick quick couplers defy even the toughest construction site conditions – we can no longer do without them!«



EXTREMELY PRODUCTIVE

Every demolition is a new challenge that can only be overcome with perfect preparation, a great deal of intuition and the accurate use of equipment. In collaboration with Kiesel and Hitachi, we have developed a quick coupler for booms that combines reach and height: Within minutes, you can switch from an earthwork boom for demolition work at ground level to a long-front boom for working on upper floors. The highlight of many machine fleets!

<p>FRAMES FOR MECHANICAL EQUIPMENT</p> <p>Inner width (mm) 590 mm Centre distance (mm) 670 mm Axle diameter (mm) 80 mm Weight (kg) approx. 144 kg</p> 	<p>FRAMES FOR HYDRAULIC EQUIPMENT</p> <p>590 mm 670 mm 80 mm approx. 176 kg</p> 	<p>SCREW ADAPTERS FOR MANY POPULAR ATTACHMENTS</p> <p>590 mm 670 mm 80 mm approx. 390 kg</p> 	<p>HYDRAULIC PENDULUM ADAPTERS</p> <p>590 mm 670 mm 80 mm approx. 225 kg</p> 								
<p>COUPLER WITH TWO PARALLEL HYDRAULIC CYLINDERS</p> <p>Max. working pressure 35 MPa Pressure retention/hose break valves yes</p>	<p>NON-DRIP QUICK COUPLERS MADE OF STEEL, OILQUICK TYPE</p> <table border="0"> <tr> <td>Coupling size</td> <td>1/2"</td> <td>3/4"</td> <td>1"</td> </tr> <tr> <td>Number of couplings</td> <td>2</td> <td>2</td> <td>2</td> </tr> </table>	Coupling size	1/2"	3/4"	1"	Number of couplings	2	2	2	<p>ELECTRIC COUPLERS (OPTIONAL) 3/4 2 x W90</p> <p>See page 36 for additional information.</p>	<p>LOAD HOOKS</p> <p>individually configurable</p>
Coupling size	1/2"	3/4"	1"								
Number of couplings	2	2	2								

OQ 80

FULLY AUTOMATIC QUICK COUPLER SYSTEM FOR MID-RANGE EXCAVATORS FROM 25 TO 43 TONNES

The quick coupler for mid-range standard excavators that are frequently used for earthmoving works and general construction projects.







OQ 90

FULLY AUTOMATIC QUICK COUPLER SYSTEM FOR LARGE EXCAVATORS FROM 40 TO 70 TONNES

The quick coupler for large excavators that need to demonstrate strength – ideal for demanding continuous use in earthmoving, construction and demolition works.







<p>FRAMES FOR MECHANICAL EQUIPMENT</p> <p>Inner width (mm) 750 mm Centre distance (mm) 749 mm Axle diameter (mm) 90 mm Weight (kg) approx. 190 kg</p> 	<p>FRAMES FOR HYDRAULIC EQUIPMENT</p> <p>750 mm 749 mm 90 mm approx. 240 kg</p> 	<p>SCREW ADAPTERS FOR MANY POPULAR ATTACHMENTS</p> <p>750 mm 749 mm 90 mm approx. 710 kg</p> 	<p>HYDRAULIC PENDULUM ADAPTERS</p> <p>750 mm 749 mm 90 mm approx. 385 kg</p> 										
<p>COUPLER WITH TWO PARALLEL HYDRAULIC CYLINDERS</p> <p>Max. working pressure 35 MPa Pressure retention/hose break valves yes</p>	<p>NON-DRIP QUICK COUPLERS MADE OF STEEL, OILQUICK TYPE</p> <table border="0"> <tr> <td>Coupling size</td> <td>1/4"</td> <td>1/2"</td> <td>3/4"</td> <td>1"</td> </tr> <tr> <td>Number of couplings</td> <td>1</td> <td>3</td> <td>1</td> <td>4</td> </tr> </table>	Coupling size	1/4"	1/2"	3/4"	1"	Number of couplings	1	3	1	4	<p>ELECTRIC COUPLERS (OPTIONAL) 1/2 2 x V90</p> <p>See page 36 for additional information.</p>	<p>LOAD HOOKS</p> <p>individually configurable</p>
Coupling size	1/4"	1/2"	3/4"	1"									
Number of couplings	1	3	1	4									

OQ 120

FULLY AUTOMATIC QUICK COUPLER SYSTEM FOR LARGE EXCAVATORS FROM 70 TO 120 TONNES

The quick coupler for XXL excavators with absolute top performance – frequently used for large volume buckets and heavy demolition equipment such as hydraulic hammers, concrete shears and large sorting grabs.



<p>FRAMES FOR MECHANICAL EQUIPMENT</p> <p>Inner width (mm) 870 mm Centre distance (mm) 925 mm Axle diameter (mm) 120 mm Weight (kg) on request</p> 	<p>FRAMES FOR HYDRAULIC EQUIPMENT</p> <p>870 mm 925 mm 120 mm on request</p> 	<p>SCREW ADAPTERS FOR MANY POPULAR ATTACHMENTS</p> <p>870 mm 925 mm 120 mm on request</p> 	<p>HYDRAULIC PENDULUM ADAPTERS</p> <p>870 mm 925 mm 120 mm on request</p> 								
<p>COUPLER WITH TWO PARALLEL HYDRAULIC CYLINDERS</p> <p>Max. working pressure 35 MPa Pressure retention/hose break valves yes</p>	<p>NON-DRIP QUICK COUPLERS MADE OF STEEL, OILQUICK TYPE</p> <table border="0"> <tr> <td>Coupling size</td> <td>1/2"</td> <td>1"</td> <td>1 1/2"</td> </tr> <tr> <td>Number of couplings</td> <td>3</td> <td>3</td> <td>2</td> </tr> </table>	Coupling size	1/2"	1"	1 1/2"	Number of couplings	3	3	2	<p>ELECTRIC COUPLERS (OPTIONAL) 1/2 2 x V90</p> <p>See page 36 for additional information.</p>	<p>LOAD HOOKS</p> <p>individually configurable</p>
Coupling size	1/2"	1"	1 1/2"								
Number of couplings	3	3	2								

SPECIAL TODAY. SERIES TOMORROW. CUSTOM PRODUCTION

We are passionate about developing innovative solutions for construction site issues. The fully automated quick coupler therefore plays a central role when initiating entirely new tools and work processes. As a family-run SME, we keep a close ear to the industry. Whether swivel motor, current feed-through or special adapter plates – many products in our range are based on tailor-made products for customers. So we are not interested in unit numbers, but in the best individual solution. But it does not always have to be a complete custom design – we are also happy to make small design modifications to enhance your quick coupler.

**THE QUICK COUPLER
IS NOT DONE
BEING INVENTED.**

Have a specific problem for the OilQuick think tank? You've got our attention!
+49 8202 9618-0

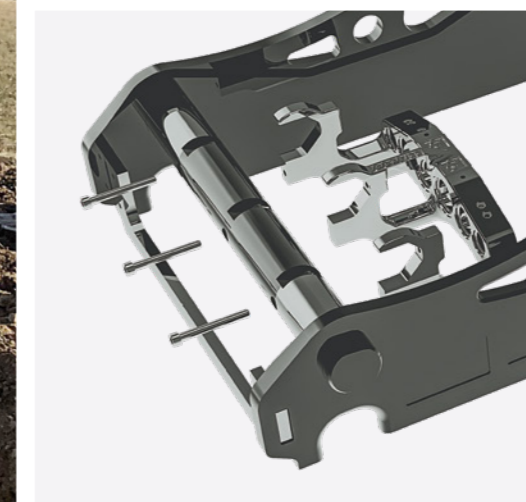
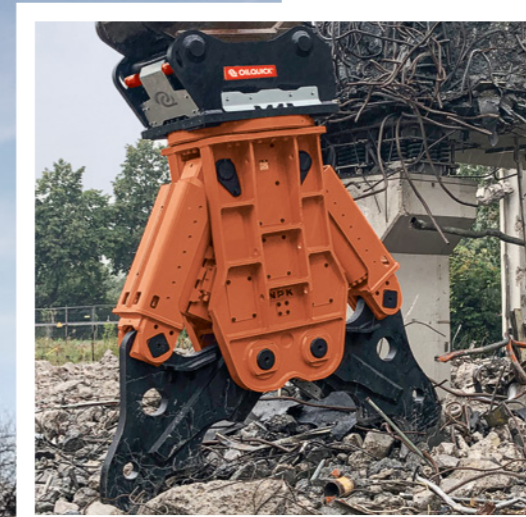

DID YOU KNOW THIS?



FOR GREATER OPERATIONAL RELIABILITY INNER HOISING

We also customize the hose layout to your attachment – for example, as an adapter plate with completely protected inner hosing.

DO IT YOURSELF REPLACEABLE COUPLING DEVICE

Coupling block damaged? The replaceable coupling block is not welded, but mounted with hexagonal socket screws. So you don't have to send your adapter plate to us for repair, but can change the module by yourself in just a few easy steps. Your attachment will be ready for use again in no time! Patent pending.

THE EXTRA TWIST SWING COUPLERS



Swing couplers take your efficiency to a new level: Instead of constantly having to shift the excavator, the attachment can simply be tilted thanks to the integrated swivelling drive – an enormous time advantage, for example when working on embankments or digging narrow trenches with the trench clearing bucket. The OilQuick swing coupler gives your attachments additional flexibility with compact dimensions, low weight and a constantly high swing torque. The housing is robust and the design is easy to maintain.



THE WRIST JOINT ON THE EXCAVATOR ARM TILT ROTATOR



Rotate endlessly in both directions and simultaneously swivel sideways up to 45°. With the OilQuick tilt rotators in a fixed attachment or as a sandwich solution, you get an ultra-movable tool. This avoids unproductive manoeuvring times, protects the ground and requires less working space. The advantage of our tilt rotator sandwich is that you can not only change the attachments on the tilt rotator under mechanical or hydraulic control, but also take off the tilt rotator itself from time to time to make maximum use of the excavator's breakaway torque.

»We are now using our OilQuick quick coupler on excavator number five, with a total of around 40,000 operating hours.«

**SUSTAINABLY
PROFITABLE**

We want to inspire you. With continuous innovation, but also with operational reliability and investment security. That's why we treat your resources responsibly and guarantee above-average service life and high value retention – including via backwards-compatible upgrades.





THE ADD-ON FOR POWER ELECTRIC COUPLERS

More and more attachments such as tilt rotators are electrically powered or require electricity for GPS tools and electrical loads such as pumps and light. With our optional electric coupling, you automatically connect the power supply and the hydraulic system when connecting the attachment. The electric coupling can be upgraded at any time.



3/4

HORIZONTALLY MOUNTED TYPE 3/4

(PLUG + SOCKET / 10-PIN)
patent pending, replaceable front part



V90

VERTICALLY MOUNTED TYPE V90

(PLUG + SOCKET / 10-PIN)

YOUR INTELLIGENT TOOLMANAGER OILQUICK TOOL CONTROL

The new Tool Control 3 assistance system identifies attachments paired with the tag reader and improves communication between the quick coupler and the tool. If the attachment has no tag, you can manually select the tool via the display.



- ✓ UNIQUE IDENTIFICATION OF ATTACHMENTS
- ✓ AUTOMATIC ADJUSTMENT OF IDEAL PRESSURE AND OIL QUANTITY
- ✓ ENABLE, SWITCH ON OR OFF ADDITIONAL FEATURES
- ✓ INTUITIVE USER INTERFACE
- ✓ OPTICAL AND ACOUSTIC COMMUNICATION OF RELEVANT DATA
- ✓ ERROR DIAGNOSTICS
- ✓ DATA TRANSFER VIA USB, BLUETOOTH, LAN OR WIFI
- ✓ DOCUMENTATION/EXPORT OF TOOL DATA
- ✓ SELF-LEARNING SYSTEM WITH EQUIPMENT DATABASE
- ✓ NON-PROPRIETARY
- ✓ CAN BE UPGRADED AT ANY TIME, MAINTENANCE AND SERVICE FRIENDLY

THE CLEAN SYSTEM NETWORK IS EXPANDING OVER 100 EFFICIENT PARTNERS

From A for ALLU Group to Z for Zeppelin Baumaschinen: Over 100 firms and rental fleets in the construction machinery sector already bear the Clean System Seal. Do you want to locate a Clean System dealer in your area? Or are you interested in a Clean System partnership? **Please get in touch!**



»The Clean System Seal is visible evidence of the high operational safety of our construction machinery, both in sales and in our rental fleet.«



SCHÜNKE BAUZENTRUM
BAUMASCHINEN GMBH



»We're continuously working on innovative solutions for maximum driver safety and improved construction site efficiency. By participating in the Clean System initiative, we're consolidating our position as a professional, reliable partner for our customers.«



ZEPPELIN
BAUMASCHINEN GMBH



»Customer focus is a central element of our corporate philosophy. The Clean System partnership highlights our above average quality and service standards.«

ALLU GROUP



»Being in good hands – is part of our mission statement. After all, our customers work in a demanding and often dangerous environment. The Clean System Seal makes an important contribution to occupational safety and therefore builds trust.«

KIESEL GMBH



»The half-day training course was just the right mix of theory and practice. I now know, for example, what in particular I have to pay attention to during maintenance and I have a better picture of dangerous situations.«



WANT TO GET EVEN BETTER? WELCOME TO THE OQ ACADEMY!

OilQuick quick couplers are purchased for their durability, reliability and efficiency. With practical training courses at the OilQuick Academy, we help our customers to take full advantage of this investment. We'll show you tricks of the trade, explain how to minimise wear and tear, and practice until you have fully mastered the safety tools. We alternate between the basics of technology and practical use, between classroom and training grounds. **The aim:** You work even more productively and safely with our quick couplers after the training course. **Tip:** We offer special sales training courses for dealers.

SIGN UP NOW AND LEARN MORE!

For machine operators, fleet managers and construction machinery mechanics. For beginners and professionals who want to get the most out of their construction site vehicles. Feel free to get in touch with us for an appointment.

+49 8202 9618-0

OILQUICK BECAUSE YOU DESERVE THE ORIGINAL!

Are you interested in the technical details or looking for a specialist OilQuick dealer? Do you need a quote or want to attend a training course at the OQ Academy? Then please get in touch. Our team will be happy to help! Or visit us at one of the forthcoming trade fairs and experience our quick couplers live – all event dates are available on our website.



OILQUICK
DEUTSCHLAND KG

Bürgermeister-Schauer-Strasse 1
82297 Steindorf
Germany



ANY QUESTIONS OR FEEDBACK? WE'RE HERE FOR YOU.

+49 8202 9618-0

www.oilquick.de
info@oilquick.de

TECHNICAL DATA QUICKSPECS

	WIDTH	CENTRE DISTANCE	WEIGHT	EXCAVATOR WEIGHT	MAX. NUMBER OF COUPLINGS	ELECTRIC
OQ 40	240	300	approx. 30 kg	1-5t	4	-
OQ 40-5	270	300	approx. 30 kg	1-6t	5	-
OQ 45-5	290	430	approx. 85 kg	5-12t	5	yes
OQ 60-5	340	480	approx. 135 kg	8-15t	5	yes
OQ 65	440	530	approx. 170 kg	14-22t	5	yes
OQ RAIL	440	530	approx. 170 kg	14-22t	8	yes
OQ 70	450	600	approx. 210 kg	15-25t	5	yes
OC 70/55	550	600	approx. 230 kg	18-32t	6	yes
OQ 80	590	670	approx. 350 kg	25-43t	6	yes
OQ 90	750	750	on request	40-70t	9	yes
OQ 120	870	925	on request	70-120t	8	yes

EVERYTHING AT A GLANCE FOLD OUT AND READ

What quick coupler variants are compatible with your type of excavator? The practical QuickSpecs table gives you direct access to the relevant technical data anywhere in the brochure and enables you to quickly find your way around. Just fold out to the side.



HOW TO FIND OUT MORE? GET THE OILQUICK IMAGE BROCHURE.

We tell you about our passion for quick couplers, what drives us and how we can make your workday better.

+49 8202 9618-0
www.oilquid.de

oilquick.de