

# CONNECT TO THE FUTURE BE BETTER

**OQTRS**  
TILTROTATORS WITH FIXED ATTACHMENT  
CONSTRUCTION

<b>1</b> WHO WE ARE	P. 3	<b>8</b> OILQUICK ACADEMY	P. 25
<b>2</b> QOTR IMAGESPOT	PP. 4-5	<b>9</b> DISPLAY E-VA AND MRL	PP. 26-27
<b>3</b> OPERATING PRINCIPLE	PP. 6-9	<b>10</b> PARTNER PROGRAMME	P. 28
<b>4</b> FUNCTION, FULLY HYDRAULIC	PP. 10-11	<b>11</b> WHAT OUR CUSTOMERS SAY	P. 29
<b>5</b> CERTIFIED SAFETY	PP. 12-13	<b>12</b> UPGRADE	P. 30
<b>6</b> OQTRF PRODUCT RANGE	PP. 16-22	<b>13</b> CONTACT	P. 31
<b>7</b> OPTIONAL EQUIPMENT	P. 24		



**QUICK COUPLER SYSTEMS FOR MAXIMUM PERFORMANCE**

# THE ORIGINAL PIONEER SINCE 1993

Almost 30 years ago, OilQuick launched the first fully hydraulic quick coupler, revolutionising the construction industry. We are still visionaries and our OilQuick solutions continue to define the state of the art. Every day, our engineers work on groundbreaking innovations like the OilQuick tiltrotator with Zero Degree Technology. **Our aim:** We develop products that improve your work.



**EFFICIENCY**  
The OilQuick tiltrotator can get into difficult to reach places, saving you time-consuming and tough manual work.

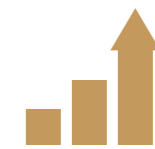

**ECONOMIC**  
The OilQuick tiltrotator-quick coupler combination allows for more intelligent work processes and shorter retooling times, meaning it pays for itself very quickly.



**SAFETY**  
We use innovative tools to redefine safety and significantly reduce the risk of workplace accidents.



**SERVICE**  
We develop individual special solutions, retrofit innovations to existing equipment and offer a worldwide network of dealers and service centres.

# THE FUTURE IS CLOSER THAN YOU THINK

We think as visionaries and utilize the most innovative technologies to make your daily life easier, safer and more efficient. For the best human-machine team in the galaxy. With the OilQuick tiltrotator you can start working on tomorrow's construction site, today. Our mission: To always stay one step ahead. **See for yourself!**



Stream the OilQuick tiltrotator image film right now



[oilquick.de/future](https://oilquick.de/future)



**SERIES: DOUBLE-ACTING HYDRAULIC CYLINDER**

with tempered piston rod and load retention valves  
(requirement for using pallet forks)

up to max. **45°** **LARGE SWIVEL ANGLE**  
*Swivelling and rotation possible at the same time*

**360°** **INFINITE ROTATION**  
*strong rotational torque*

**PIPING**

Unique and well-thought-out piping system that protects against damage

**OQ QUICK COUPLER**

**DROP GUARD**

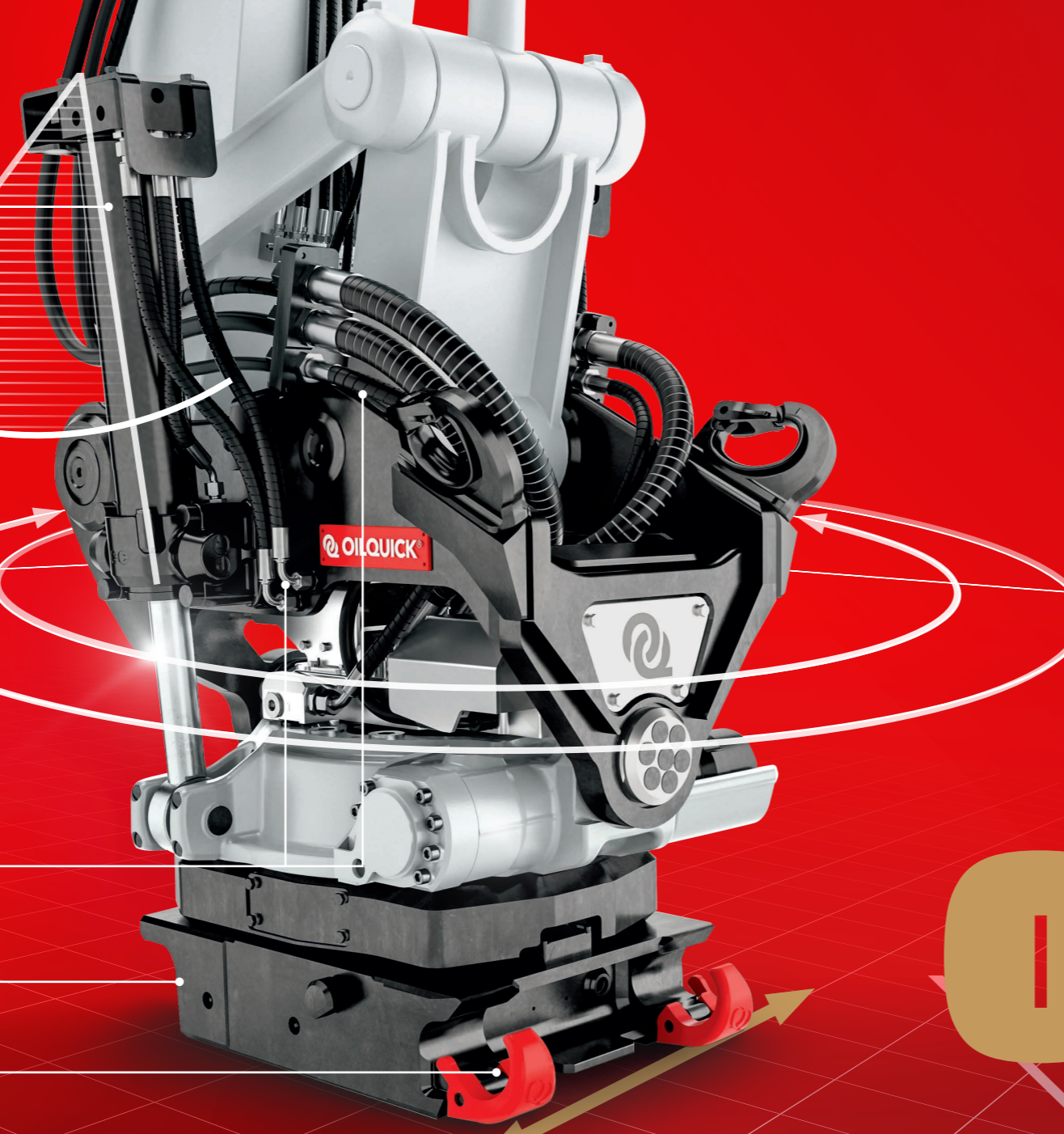

**QUICK AND SMART: THE OQTRF TILTROTATOR**

- ✓ **HIGH-SPEED ROTATION**
- ✓ **PROTECTED HYDRAULIC CONNECTIONS**
- ✓ **YOU CAN NOW USE HAMMER AND MILLING DEVICES WITHOUT LIMITATIONS**
- ✓ **LOWER WEIGHT**
- ✓ **LOW CONSTRUCTION HEIGHT**

**0** **ZERO-DEGREE-TECHNOLOGY**  
*New: OilQuick tiltrotator with the revolutionary zero degrees standard*

**FOR EVERYONE WITH BIG PLANS WE BOOST YOUR PRODUCTIVITY!**

Rotate endlessly in both directions and simultaneously swivel sideways up to 45°. Our OQTR Series tiltrotators allow you to bring attached tools to any desired position. With the fixed design, we combine the proven OilQuick tiltrotator system from our cooperation partner engcon with the OilQuick quick coupler technology above and below the OilQuick tiltrotator. A fixed tiltrotator is often used where you want to make use of the advantages of tilting and rotating with your excavator during almost any work process – for example if you mostly work on sites where space is tight.

For excavators from 4 to 33 tonnes. Also available with sandwich construction (OQTRS).

All OQTR-E models can optionally be delivered with an ePS module for connection to common GPS systems.

# BE BALANCED BE BETTER



SUPPORTED BY LEADING PARTNERS WITHIN THE SECTOR:

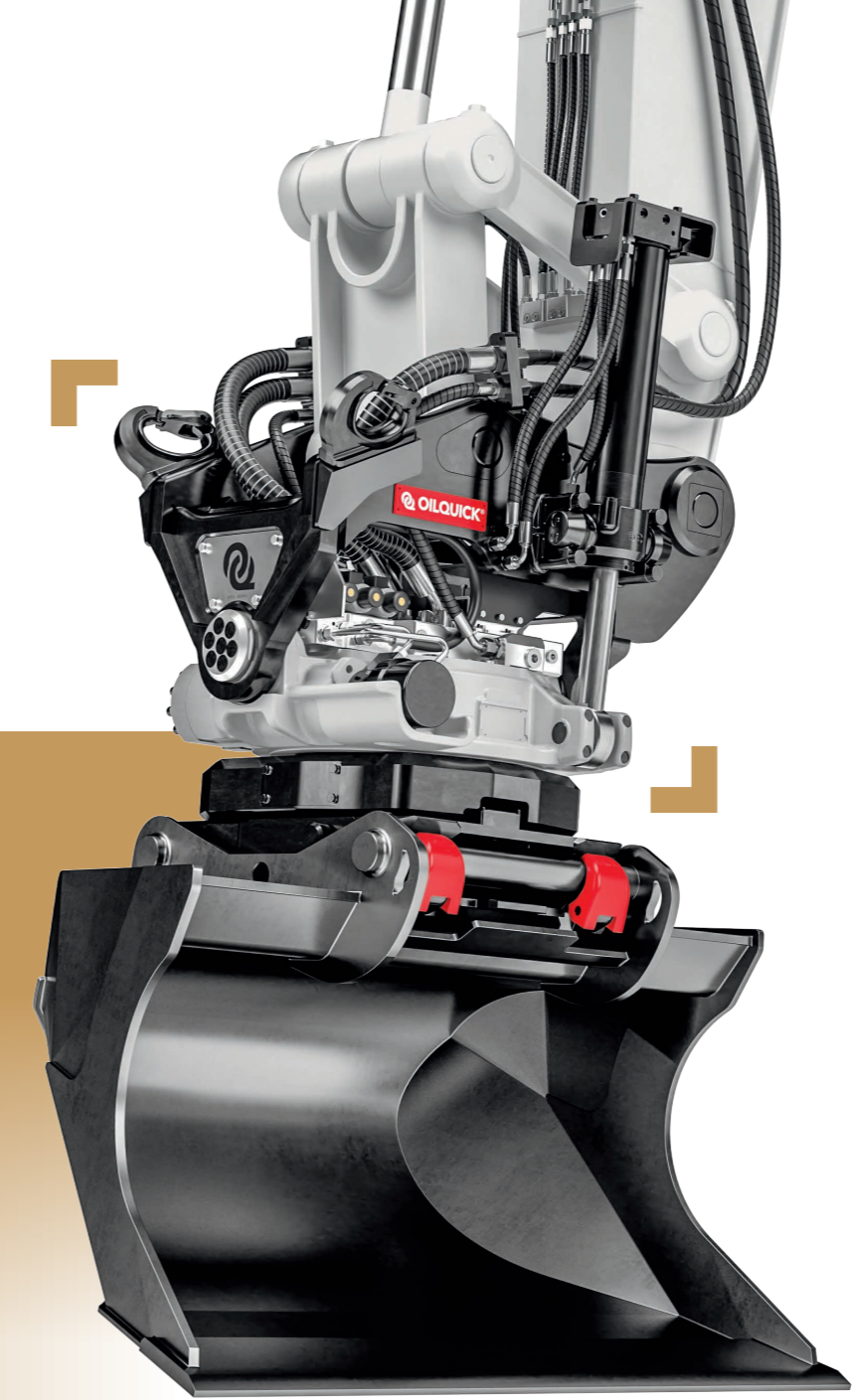
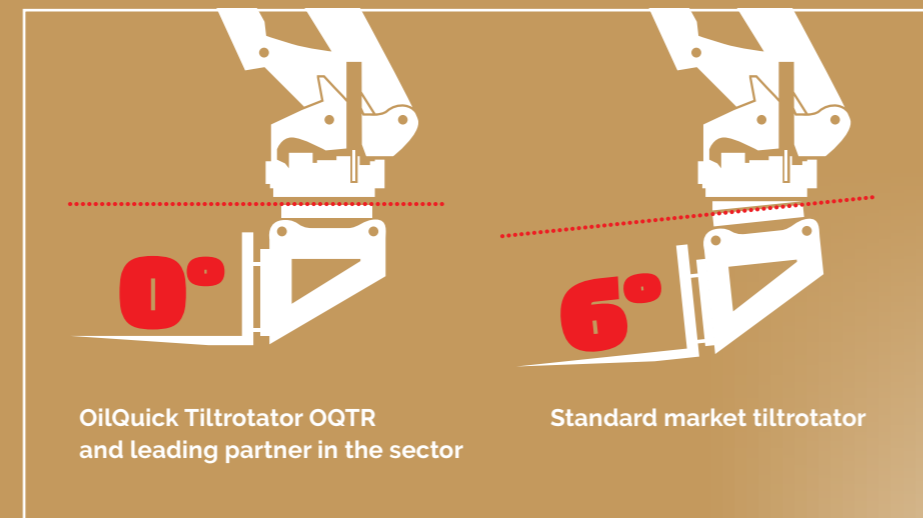

## TILTROTATOR WITH ZERO DEGREE TECHNOLOGY

- ✓ **Full compatibility:** The previously standard 6° tilt of the rotation level no longer applies. You can use any conventional attachment with any manufacturer.
- ✓ **Simple to operate:** From now on, the machine operator no longer needs to correct for any rocking of the attachment – ensures the tiltrotator is a pleasure to work with.
- ✓ **Better safety:** The Zero Degree Technology reduces both the time needed to start working with the device and the risk of accident, thus contributing to better health and safety on your construction site.



Zero4Hero.de



# OQTRF TILTROTATOR WELL EQUIPPED THANKS TO HIGH FLOW EXPERTISE



## DID YOU KNOW?

With our modular hydraulic platform we adapt the OilQuick tiltrotator to your excavators control system – not the other way round. No need to make changes to your joystick and without any risk to your CE certification.

Fixed OilQuick tiltrotators are fully hydraulic. Attachments are locked and unlocked at the push of a button and, at the same time, the oil lines are coupled. Thanks to OilQuick High Flow expertise, even high-speed hydraulic tools can now be supplied with maximum performance so that attachments such as mulchers, millers and vibrating plates can be used without limitations. Another advantage: The unique, integrated piping of our OilQuick tiltrotator offers maximum, and permanent, process reliability.

- ✓ **OPTIMAL OIL SUPPLY EVEN FOR HIGH-SPEED ATTACHMENTS**
- ✓ **APPROVED FOR HAMMERS AND MILLING CUTTERS WITHOUT LIMITATIONS**
- ✓ **HEAVY DUTY SAE CONNECTION: RELIABLE CONNECTION OF THE HIGH PRESSURE LINES**
- ✓ **EASY TO MAINTAIN SYSTEM**
- ✓ **PATENTED ROTARY FEED-THROUGH WITH SHOCKPROOF AND IMPACT RESISTANT BEARING**
- ✓ **HIGH AVAILABILITY OF SPARE PARTS**
- ✓ **ROTARY FEEDTHROUGH ADJUSTED TO THE SPECIFIC TILT ROTATOR SIZE**

# AWARD-WINNING OCCUPATIONAL SAFETY INNOVATIONS AT THE CUTTING EDGE OF THE SECTOR

Our engineers are continuously developing the OilQuick quick coupler. We have your back – with well thought-out user functions, advanced occupational safety ideas and digital features. This also impress experts in the field: Berufsgenossenschaft der Bauwirtschaft (BG Bau, statutory accident insurance for construction and construction-related services in Germany) awarded OilQuick the EuroTest Prize 2019 for its "outstanding technical occupational safety and product safety" achievements.



## YOUR SAFETY REDEFINED

- VISUAL DISPLAY
- DROP GUARD
- ZERO DEGREE TECHNOLOGY
- CLEAN SYSTEM



## SAFER: DROP GUARD

Incorrectly mounted attachment? Accidentally opened locking bolts? The OilQuick drop guard reliably prevents your attachments from falling.



## MORE SUSTAINABLE: CLEAN SYSTEM

From A for ALLU Group to Z for Zeppelin Baumaschinen GmbH: More than 200 partners in the construction machinery sector are already working with us to promote homogeneous quick coupler systems.



## MORE EFFICIENT: OILQUICK APP

Smartphones and tablets have long been part of the standard toolbox of machine operators and service technicians. In our OilQuick App you will find many practical digital services for your quick coupler!



## SMARTER: MRL AND E-VA DISPLAY

Both versions of the OilQuick display make locking control easier and safer than ever before. Mechanical pin or LEDs – the choice is yours.



# BE A PART OF BE BETTER

The variety of systems has grown along with the rising success of the quick coupler – and with it the number of possible system combinations. Practice shows that mixed operation of this type creates unforeseeable complications, even at safety-related interfaces.

Which is why we introduced the Clean System Seal in 2019: Over 200 dealers and rental fleets have already voluntarily undertaken to not combine OilQuick quick couplers with products from other manufacturers and to only use genuine spare parts. Because when we guarantee your safety, for us this also means the smooth operation and long service life of our quick couplers.

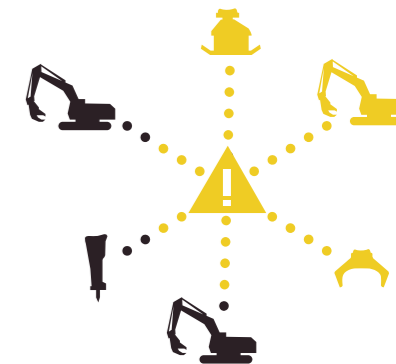

Danger of contamination during mixed operation

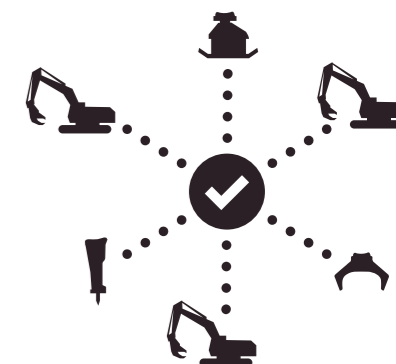

A clean, homogeneous system

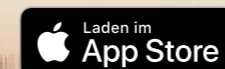

# UNDENIABLY EFFICIENT

Our OilQuick tiltrotator with quick coupler is your flexible "wrist", and lets you not only expand the uses of your excavator, but also saves you time and money. Work in places that are normally hard to reach and save yourself difficult manual work.

*»With the OilQuick tiltrotator we have to do much less switching around. We are able to work faster, save more fuel and be more environmentally friendly.«*



## IN FIGURES

Among other things, the efficiency of excavation and filling work in structural and civil engineering is cut by up to half!



# OQTRF

## THE UNIVERSAL JOINT FOR YOUR EXCAVATOR

For digging around obstacles, filling with maximum precision or creating models to that are gentle on the substrate: The OilQuick tiltrotator enables maximum freedom of movement and quick tool changes without implements. For excavators from 4 to 33 tonnes service weight, for structural and civil engineering, for landscaping and platform construction, road and sewer work.



**DOES YOUR HUMAN-MACHINE TEAM NEED AN UPGRADE?**

Simply scan the QR code.



# OQTRF-E06

## TILTROTATOR FOR ALL EXCAVATORS FROM 4 TO 6 t

The OilQuick tiltrotator for smaller compact excavators

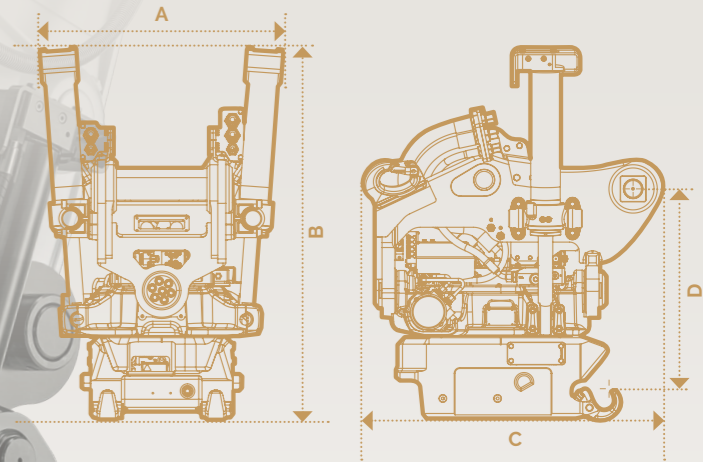

### TECHNICAL DATA

- Max. scoop width 1.2 m
- Max. breakaway torque 45 kNm
- Weight (kg) from 280 kg
- swivel angle up to 2 x 45°
- Swivel time for 90° 3 sec. at 15 l/min
- Rotation infinite
- Rotation speed / revolution 6.5 sec. at 30 l/min

**CONTROL SYSTEM**  
according to requirements

**INCLUDING:**  
High Flow rotary feedthrough  
modular valve platform  
fully hydraulic OilQuick coupler

**TIPPING CYLINDER:**  
double-acting with load retention valve

**CENTRAL LUBRICATION:**  
of a central lubrication point

**ROTOR:**  
infinite rotation in both directions

### DIMENSIONS

- OQ45-4/-5**
- Dim. (A) 570 mm
- Dim. (B) 860 mm
- Dims. (C) and (D) manufacturer dependent

Technical specifications and weights may vary for all models depending on the machine-tiltrotator configuration. Please contact our service team if you have any specific questions.

# OQTRF-E09

TILTROTATOR FOR ALL EXCAVATORS FROM 6 TO 9 t

The OilQuick tiltrotator for compact excavators

**TECHNICAL DATA**

Max. scoop width	1.3 m
Max. breakaway torque	74 kNm
Weight (kg)	from 285 kg
swivel angle	up to 2 x 45°
Swivel time for 90°	3 sec. at 35 l/min
Rotation	infinite
Rotation speed / revolution	7 sec. at 40 l/min

**DIMENSIONS**

<b>OQ45-4/-5</b>	
Dim. (A)	680 mm
Dim. (B)	980 mm
Dims. (C) and (D)	manufacturer dependent

**CONTROL SYSTEM:**

according to requirements

**INCLUDING:**

- High Flow rotary feedthrough
- modular valve platform
- fully hydraulic OilQuick coupler

**TIPPING CYLINDER:**

double-acting with load retention valve

**CENTRAL LUBRICATION:**

one central lubrication point

**ROTOR:**

infinite rotation in both directions

**OQ60-4/-5**

Dim. (A)	740 mm
Dim. (B)	1020 mm
Dims. (C) and (D)	manufacturer dependent

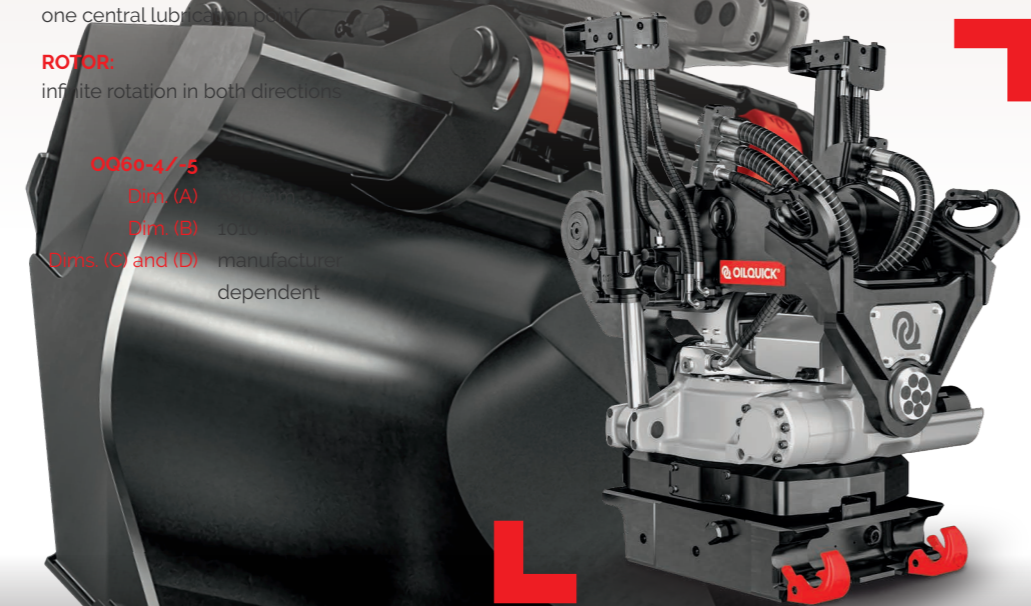
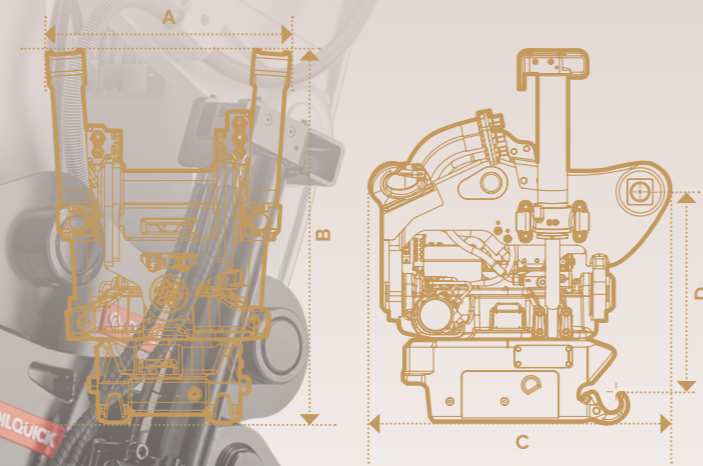

# OQTRF-E14

TILTROTATOR FOR ALL EXCAVATORS FROM 9 TO 14 t

The OilQuick tiltrotator for lightweight mid-range excavators

**TECHNICAL DATA**

Max. scoop width	1.6 m
Max. breakaway torque	126 kNm
Weight (kg)	from 300 kg
swivel angle	up to 2 x 45°
Swivel time for 90°	3 sec. at 35 l/min
Rotation	infinite
Rotation speed / revolution	7 sec. at 50 l/min

**DIMENSIONS**

<b>OQ45-4/-5</b>	
Dim. (A)	740 mm
Dim. (B)	1020 mm
Dims. (C) and (D)	manufacturer dependent

**CONTROL SYSTEM:**

according to requirements

**INCLUDING:**

- High Flow rotary feedthrough
- modular valve platform
- fully hydraulic OilQuick coupler

**TIPPING CYLINDER:**

double-acting with load retention valve

**CENTRAL LUBRICATION:**

one central lubrication point

**ROTOR:**

infinite rotation in both directions

**OQ60-4/-5**

Dim. (A)	740 mm
Dim. (B)	1020 mm
Dims. (C) and (D)	manufacturer dependent

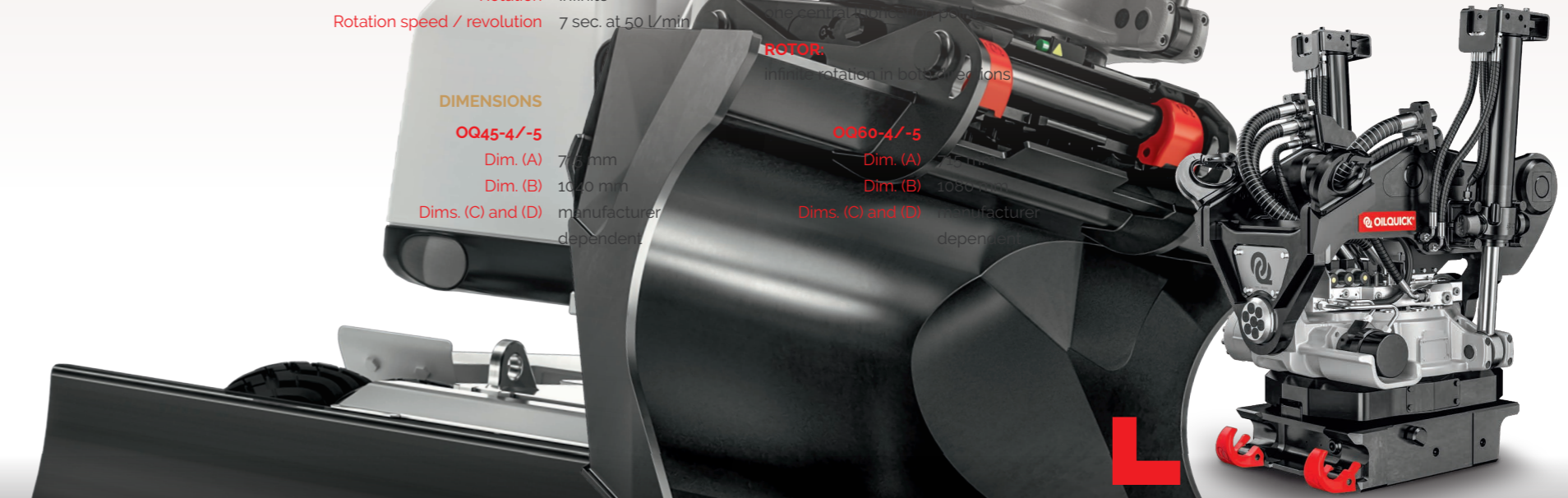
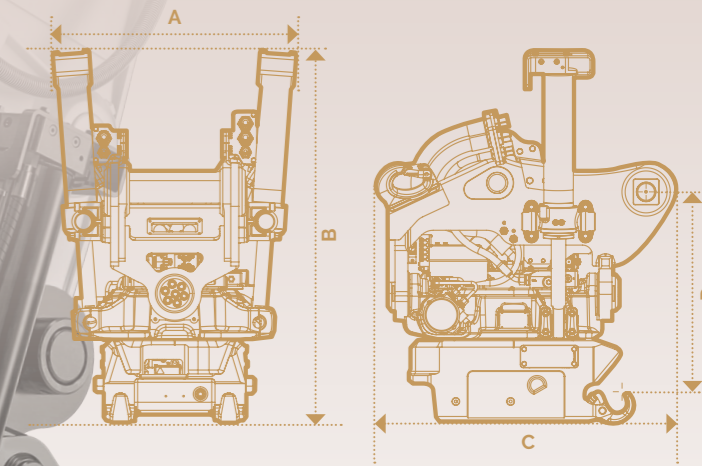

# OQTRF-E19

TILTROTATOR FOR ALL EXCAVATORS FROM 14 TO 19 t

The OilQuick tiltrotator for mid-range excavators with a wide range of applications

**TECHNICAL DATA**

Max. scoop width	1.7 m
Max. breakaway torque	186 kNm
Weight (kg)	from 460 kg
swivel angle	up to 2 x 45°
Swivel time for 90°	3 sec. at 65 l/min
Rotation	infinite
Rotation speed / revolution	6 sec. at 70 l/min

**DIMENSIONS**

<b>OQ60-4/-5</b>	<b>OQ65/RAIL</b>	<b>OQ70/55</b>
Dim. (A) 752 mm	Dim. (A) 752 mm	Dim. (A) 752 mm
Dim. (B) 1145 mm	Dim. (B) 1150 mm	Dim. (B) 1180 mm
Dims. (C) and (D) manufacturer dependent	Dims. (C) and (D) manufacturer dependent	Dims. (C) and (D) manufacturer dependent

**CONTROL SYSTEM:**

according to requirements

**INCLUDING:**

- High Flow rotary feedthrough
- modular valve platform
- fully hydraulic OilQuick coupler

**TIPPING CYLINDER:**

double-acting with load retention valve

**CENTRAL LUBRICATION:**

one central lubrication point

**ROTOR:**

infinite rotation in both directions

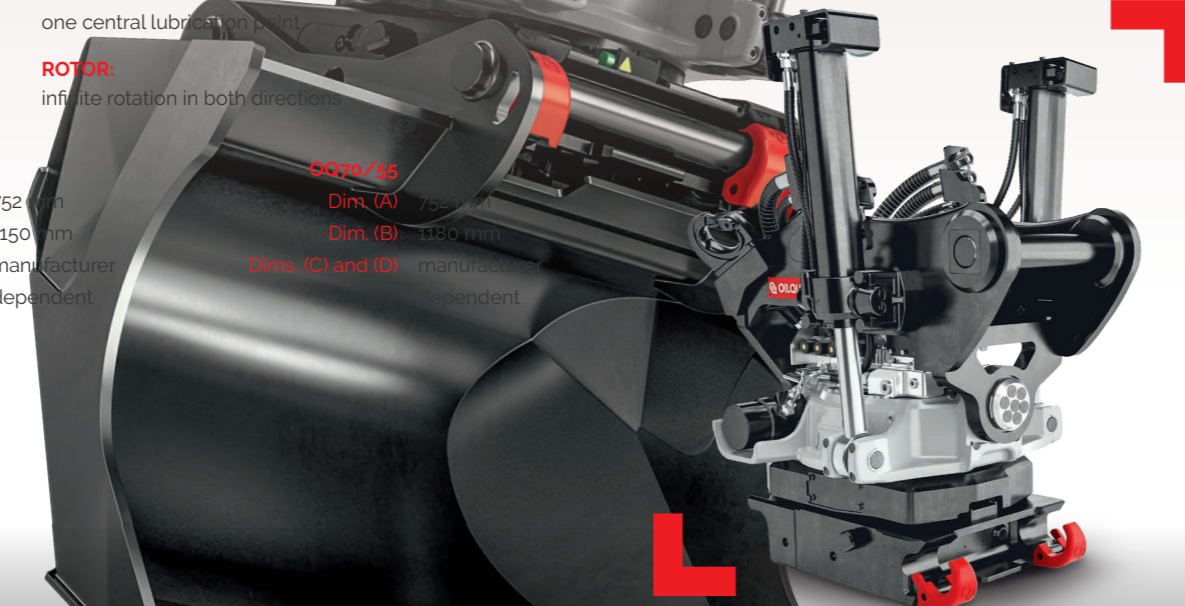
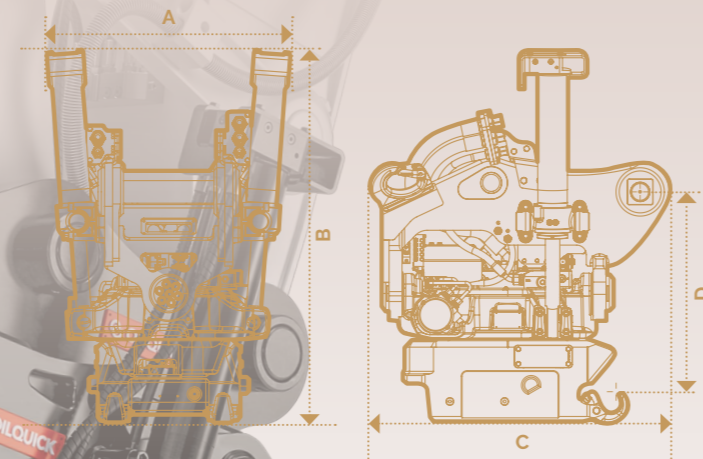

# OQTRF-E26

TILTROTATOR FOR ALL EXCAVATORS FROM 19 TO 26 t

The OilQuick tiltrotator for powerful mid-range excavators

**TECHNICAL DATA**

Max. scoop width	2.0 m
Max. breakaway torque	270 kNm
Weight (kg)	from 580 kg
swivel angle	up to 2 x 45°
Swivel time for 90°	5 sec. at 70 l/min
Rotation	infinite
Rotation speed / revolution	7 sec. at 70 l/min

**DIMENSIONS**

<b>OQ65/RAIL</b>	<b>OQ70</b>	<b>OQ70/55</b>
Dim. (A) 895 mm	Dim. (A) 895 mm	Dim. (A) 895 mm
Dim. (B) 1210 mm	Dim. (B) 1220 mm	Dim. (B) 1240 mm
Dims. (C) and (D) manufacturer dependent	Dims. (C) and (D) manufacturer dependent	Dims. (C) and (D) manufacturer dependent

**CONTROL SYSTEM:**

according to requirements

**INCLUDING:**

- High Flow rotary feedthrough
- modular valve platform
- fully hydraulic OilQuick coupler

**TIPPING CYLINDER:**

double-acting with load retention valve

**CENTRAL LUBRICATION:**

one central lubrication point

**ROTOR:**

infinite rotation in both directions

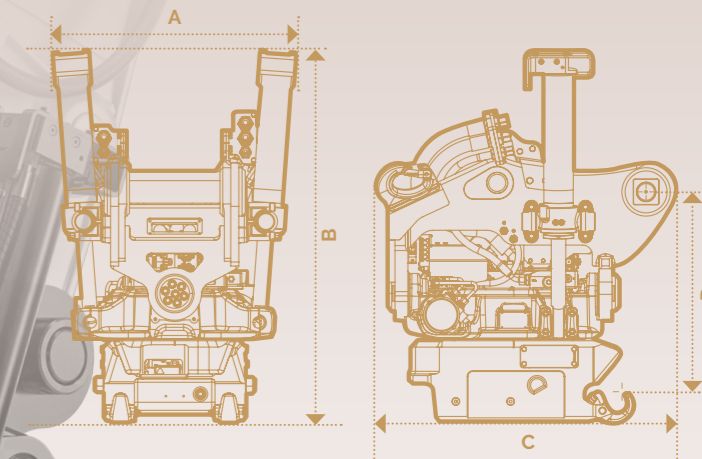

# OQTRF-E33

**TILTROTATOR FOR ALL EXCAVATORS FROM 24 TO 33 t**

The OilQuick tiltrotator for larger excavators

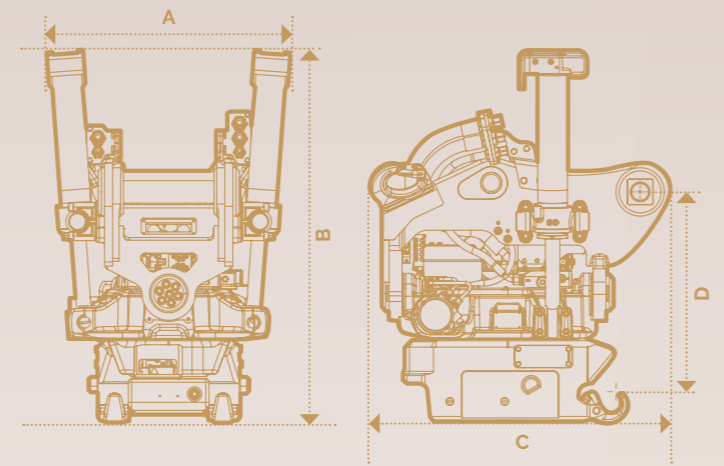

**TECHNICAL DATA**

- Max. scoop width 2.2 m
- Max. breakaway torque 340 kNm
- Weight (kg) from 900 kg
- swivel angle up to 2 x 45°
- Swivel time for 90° 5 sec. at 70 l/min
- Rotation infinite
- Rotation speed / revolution 7 sec. at 70 l/min

**CONTROL SYSTEM:**

according to requirements

**TIPPING CYLINDER:**

double-acting with load retention valve

**CENTRAL LUBRICATION:**

one central lubrication point

**ROTOR:**

infinite rotation in both directions

**INCLUDING:**

- High Flow rotary feedthrough
- modular valve platform
- fully hydraulic OilQuick coupler

**DIMENSIONS**

	<b>OQ70</b>	<b>OQ70/55</b>	<b>OQ80</b>
Dim. (A)	1010 mm	1070 mm	1110 mm
Dim. (B)	1305 mm	1320 mm	1310 mm
Dims. (C) and (D)	manufacturer dependent	manufacturer dependent	manufacturer dependent



*»The flexibility of the OilQuick tiltrotator not only saves many mechanical work steps, but also relieves our employees of heavy manual work with shovel and spade.«*



**SUSTAINABLY PROFITABLE**

We want to inspire you. With continuous innovation, but also with operational reliability and investment security. That's why we treat your resources responsibly and guarantee above-average service life and high value retention.

# SPECIAL TODAY, STANDARD TOMORROW. CUSTOM PRODUCTIONS

Our great passion is developing innovative solutions for construction site issues. The fully automated quick coupler therefore plays a central role when initiating entirely new tools and work processes. Many OilQuick products are based on special designs for customers or on suggestions from retail trade. So we are not interested in unit numbers, but in the best individual solution.

**WE EXPAND OUR THINKING. AND WOULD BE HAPPY TO DO SO WITH YOU.** Have a special requirement for the OilQuick think tank? You've got our attention!  
**+49 8202 9618-0**



**PRECISION PLUS EPS**  
All models of the OQTRF-E can optionally be delivered with ePS (engcon Positioning System): Together with the excavator's GPS control system or a 3D system, you'll receive maximum control over the positioning of the attachments on the OilQuick tiltrotator, such as the price tilt and rotation of the scoop.

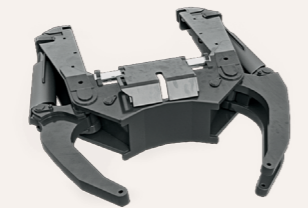

**THE ADD-ON FOR GRIPPING WORK GRIPPER CLAMP**  
The gripper module with 3-finger claw is an integrated tool for picking up and handling materials such as pipes or stones.



**WHOEVER NEEDS IT ADAPTER FOR GRIPPER**  
Many tiltrotators integrate a gripper as standard. We deliberately take a different path: Using our optional adapter, you can stay flexible, save weight and benefit from a low attachment height.



# WANT TO GET EVEN BETTER? WELCOME TO THE OQ ACADEMY!

OilQuick products are purchased for their durability, reliability and efficiency. With practical training courses at the OilQuick Academy, we help our customers to take full advantage of this investment. We'll show you tricks of the trade for operation, explain how to minimise wear and tear, and practice until you have fully mastered the safety tools. We alternate between the basics of technology and practical use, between classroom and training grounds. **The aim:** You work even more productively and safely with your quick coupler-tiltrotator combination after the training course. **Tip:** We offer special sales training courses for dealers.

 **SIGN UP NOW AND LEARN MORE!**

For machine operators, fleet managers and construction machinery mechanics. For beginners and professionals who want to get the most out of their construction site vehicles. Please get in touch with us for an appointment.

**+49 8202 9618-0**

# E-VA & MRL INDICATOR DISPLAY

## THE CHOICE IS YOURS

### DOUBLE PROTECTION WITH E-VA

The e-VA electronic locking indicator is a further development of our award-winning MRL display. Instead of a mechanical pin, a green LED strip on the arm indicates the locking status – even in poor lighting conditions or at night, it is easily visible to the machine operator and construction site personnel within the hazardous area around the machine.

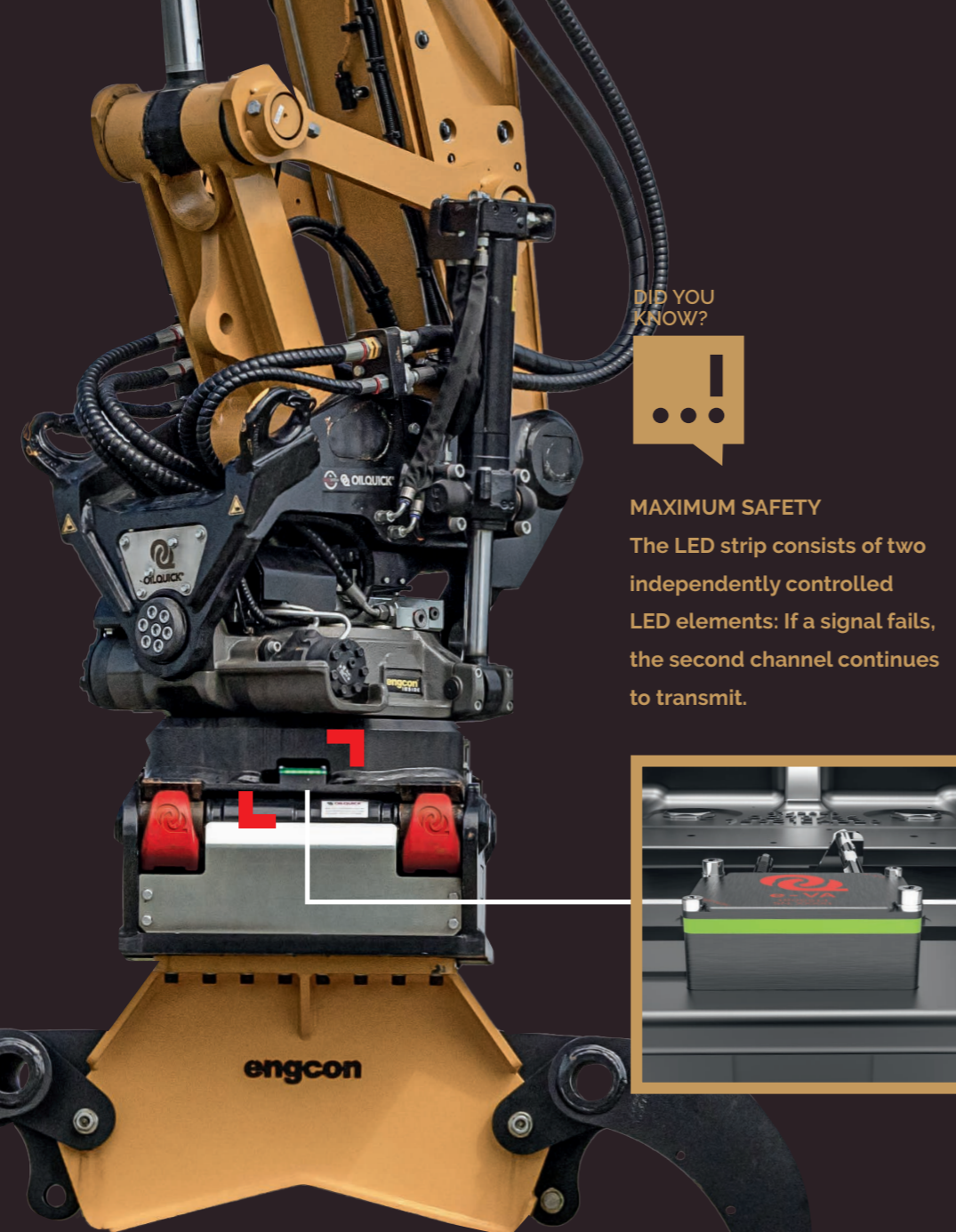

DID YOU KNOW?



#### MAXIMUM SAFETY

The LED strip consists of two independently controlled LED elements: If a signal fails, the second channel continues to transmit.



### A QUICK GLANCE IS ENOUGH WITH MRL

"Simple and robust, please!" That was the locking control requirement of the machine operators we surveyed. Implementation was a bit tricky. In order to rule out misinterpretations, the usual combinations of different coloured pins for different locking situations in use until now were out of the question. Our visual MRL display has a very decisive advantage: There is only one pin and one colour – and only a single correct status on the visual display. Our visual MRL display allows you to quickly and clearly see whether the quick coupler is locked correctly. **Another advantage:** From the machine operator's point of view, the large pin moves horizontally and is thus 650 percent more easily perceived.

The visual MRL display is a standard feature of all newly delivered OilQuick quick couplers and can also be retrofitted.

DID YOU KNOW?



The OilQuick visual MRL display in combination with the OilQuick drop guard, is subsidised by BG Bau and can be retrofitted to existing systems at any time.

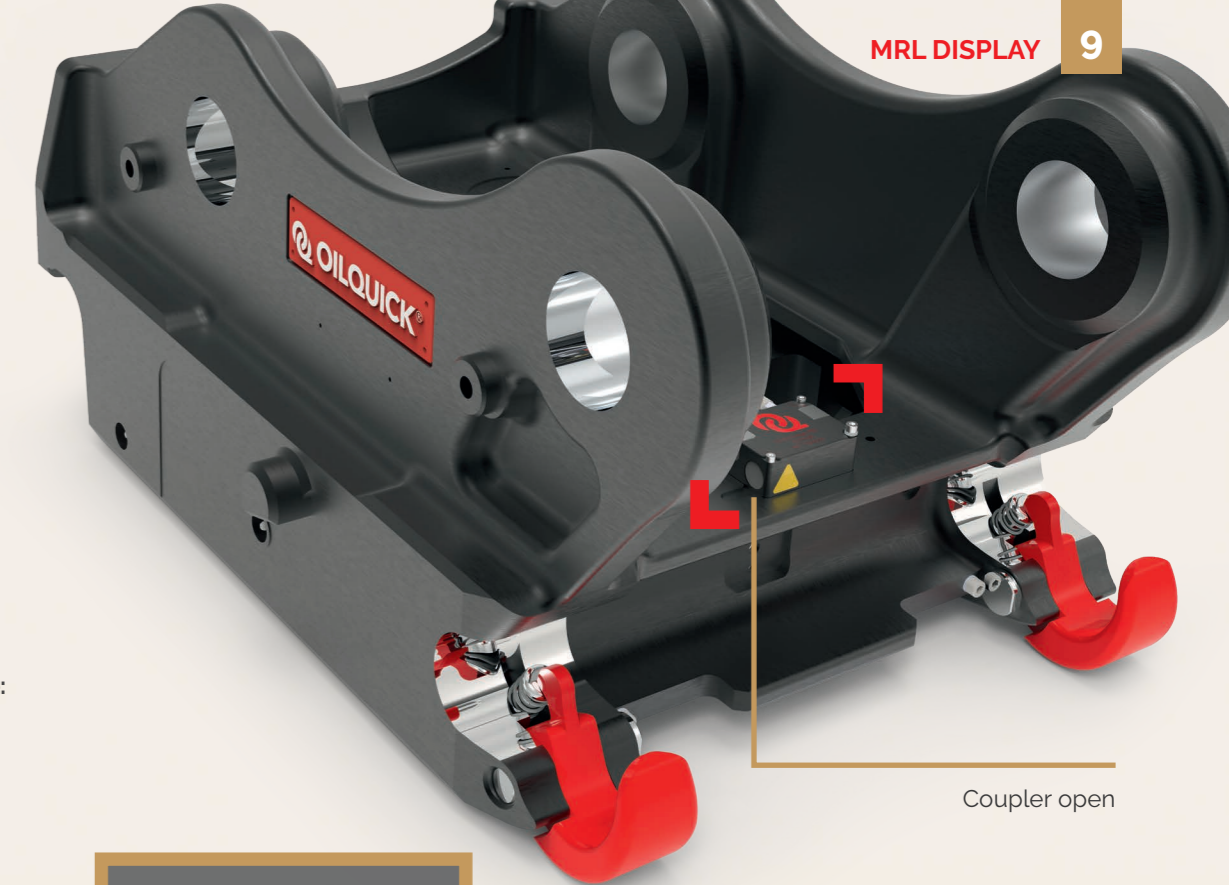

Coupler open



Coupler correctly locked

# CLEAN SYSTEM A STRONG COMMUNITY

From A for ALLU Group to Z for Zeppelin Baumaschinen:  
Over 200 firms and rental fleets in the construction  
machinery sector already bear the Clean System Seal.  
Do you want to locate a Clean System dealer in your  
area? Or are you interested in a Clean System partnership?  
**Please get in touch!**

Coordination:  
**Anna Betz**  
+49 8202 9618 – 132  
anna.betz@oilquick.de



*"The Clean System Seal is visible evidence of the high level of operational safety of our construction machinery, both in sales and in our rental fleet."*

SCHÜNKE BAUZENTRUM  
BAUMASCHINEN GMBH



*"Customer focus is a central element of our corporate philosophy. The Clean System partnership highlights our above average quality and service standards."*

ALLU GROUP

*"Clean System is the answer to growing customer requirements for safety. The single source approach not only ensures the CE mark is protected, and therefore also issues of guarantee and liability, but also the operational readiness and efficiency of the machines. With homogenous systems both we and our customers are on the safe side."*

ZEPPELIN  
BAUMASCHINEN GMBH



*"Quality, safety and sustainability are important aspects of our guiding principles. It is for this reason that we specifically chose OilQuick to be our quick coupler product partner. The support of a homogenous system landscape contributes to this aim and Clean System participation was a consistent step for us."*

KIESEL GMBH

# OILQUICK BECAUSE YOU DESERVE THE ORIGINAL!

Are you interested in the technical details or looking for a specialist OilQuick dealer? Do you need a quote or want to attend a training course at the OilQuick Academy? Then please get in touch. Our team will be happy to help! Or visit us at one of the forthcoming trade fairs and experience our tiltrotators live – all event dates are available on our website.



OILQUICK  
DEUTSCHLAND KG

Bürgermeister-Schauer-Straße 1  
82297 Steindorf  
Deutschland



# EVEN MORE FLEXIBILITY: OQTRS TILTROTATOR

One quick coupler above and one quick coupler below the OilQuick tiltrotator: Thanks to the sandwich construction, not only can you swap out the attachments, but also place down the OilQuick tiltrotator in order to get maximum performance from your excavator – or to protect the tiltrotator during extremely tough tasks.

**ANY QUESTIONS OR FEEDBACK?  
WE'RE HERE FOR YOU.**

**+49 8202 9618-0  
info@oilquick.de  
oilquick.de**





[oilquick.de/future](https://oilquick.de/future)

**DOES YOUR HUMAN-MACHINE  
TEAM NEED AN UPGRADE?  
REQUEST A PERSONAL  
CONSULTATION NOW**